

## API Grade API Subcoupling

### Dimensions:

#### Full Size:

Nominal Size	Units	OD	Lc* (min)	Weight
3/4"-5/8"	in	1.625	4.000	1.65 lb
	mm	41.3	101.6	(0.750 kg)
7/8"-5/8"	in	1.811	4.000	2.14 lb
	mm	46.0	101.6	(0.969 kg)
7/8"-3/4"	in	1.811	4.000	2.04 lb
	mm	46.0	101.6	(0.923 kg)
1"-3/4"	in	2.189	4.500	3.25 lb
	mm	55.6	114.3	(1.473 kg)
1"-7/8"	in	2.189	4.500	3.15 lb
	mm	55.6	114.3	(1.429 kg)
1 1/8"-7/8"	in	2.375	5.000	4.41 lb
	mm	60.3	127.0	(2.000 kg)
1 1/8"-1"	in	2.375	5.000	4.19 lb
	mm	60.3	127.0	(1.900 kg)

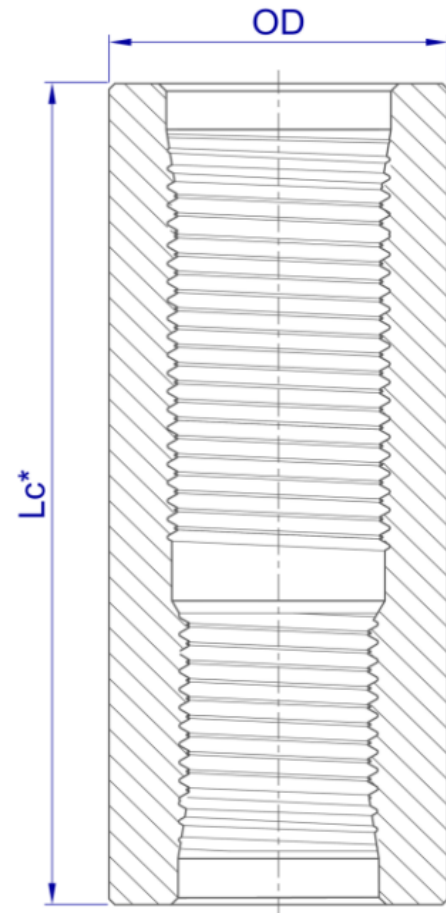

\*Other lengths might be available.

#### Slim Hole:

Nominal Size	Units	OD	c* (min)	Lc* (min)	Weight	Weight
3/4"-5/8"	in	1.500		4.000	1.26 lb	
	mm	38.1		101.6	(0.573 kg)	
7/8"-5/8"	in	1.626		4.000	1.49 lb	
	mm	41.3		101.6	(0.675 kg)	
7/8"-3/4"	in	1.626		4.000	1.4 lb	
	mm	41.3		101.6	(0.636 kg)	
1"-3/4"	in	2.000		4.500	2.41 lb	
	mm	50.8		114.3	(1.092 kg)	
1"-7/8"	in	2.000		4.500	2.31 lb	
	mm	50.8		114.3	(1.050 kg)	
1 1/8"-7/8"	in	2.256		5.000	3.75 lb	
	mm	57.3		127.0	(1.700 kg)	
1 1/8"-1"	in	2.256		5.000	3.53 lb	
	mm	57.3		127.0	(1.600 kg)	

### Steel Grades:

#### Chemical Composition:

Typical chemical compositions (wt%) are listed in the following table.

Grade	C	Mn	Si	S	P	Cr	Ni	Mo	Others
T alloy	0.28-0.33	0.70-0.95	0.15-0.34	0.020 max	0.020 max	0.40-0.65	0.40-0.70	0.15-0.25	-

## Mechanical Properties:

Mechanical properties are listed in the following table.

Grade	Yield Strength	Ultimate Tensile Stress	Hardness
T alloy	72 to 110 kpsi (500 to 757 MPa)	95 to 125 kpsi (655 to 861 MPa)	56-62 HRA

## Other Technical Data:

All the dimensions comply with API 11B, except for all the 1 1/8" SH combinations.

## Marking:

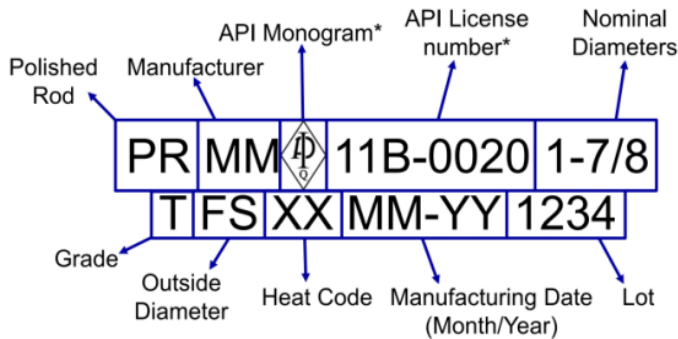

\*If applicable

## Non Destructive Testing:

All raw material is carefully inspected using electromagnetic and/or ultrasonic methods to ensure the soundness of the final product.

## Labeling:\*

		Metalmecánica S.A. Ruta 55 Km. 754,1 Villa Mercedes (San Luis) Made in Argentina	
		<b>BOX N° 60000006</b>	
PRODUCT:			
SPECIFICATION:			
QTY:	DATE:		
DIAM 1: (in)	DIAM 2: (in)		
CLASS:	TYPE:		
CLIENT:			
SALES ORDER:		NET WEIGHT: (kg)	
DESTINATION:			

\*Image for reference only

## Ordering Information:

When placing an order please attach the following information:

**PDS:** SRSCAPI  
**Coupling Type:** Coupling  
**Nominal dimension:** 1 1/8"-1"  
**Size:** Full Size  
**Grade:** T alloy

Tenaris has issued this document for general information only, and the information in this document is not intended to constitute professional or any other type of advice or recommendation and is provided on an "as is" basis. No warranty is given. Tenaris has not independently verified any information –if any- provided by the user in connection with, or for the purpose of, the information contained hereunder. The use of the information is at user's own risk and Tenaris does not assume any responsibility or liability of any kind for any loss, damage or injury resulting from, or in connection with any information contained hereunder or any use thereof. The information in this document is subject to change or modification without notice. Tenaris's products and services are subject to Tenaris's standard terms and conditions or otherwise to the terms resulting from the respective contracts of sale or services, as the case may be. Unless specifically agreed under such contract of sale or services, if Tenaris is required to provide any warranty or assume any liability in connection with the information contained here under, any such warranty or liability shall be subject to the execution of a separate written agreement between petitioner and Tenaris. For more complete information please contact a Tenaris's representative or visit our website at [www.tenaris.com](http://www.tenaris.com). All rights reserved. ©Tenaris 2024